

Matters needing attention:

- Please read this manual carefully before use and keep it for future reference.
- The equipment list should be checked carefully before use. If in doubt, contact Thinkcar Tech Inc immediately.
- Due to the continuous upgrading of the product, the manual and the physical have a slight difference, without notice, please prevail in kind.

All rights reserved! This manual may not be reproduced or backed up in any form (electronic, mechanical, photocopying, recording or otherwise) by any company or individual without the written consent of Thinkcar Tech Inc (hereinafter referred to as "Thinkcar"). This manual is designed for the use of Thinkcar products and Thinkcar assumes no responsibility for the consequences of using it as a guide for the operation of other equipment.

Thinkcar and its affiliates shall not be liable for any costs and expenses incurred as a result of damage to or loss of the equipment due to accidents, abuse or misuse of the equipment, unauthorized alterations or repairs to the equipment, or failure to comply with Thinkcar's operation and maintenance requirements, whether by the user or a third party.

Thinkcar is not responsible for any damages or problems caused by the use of other optional accessories or consumables other than Thinkcar's original products or Thinkcar's approved products.

Official Disclaimer: All other product names mentioned in this manual are intended to illustrate how the equipment is used and remain registered trademarks of their respective companies.

This equipment is intended for use by specialized technicians or maintenance personnel.

Registered Trademarks

Thinkcar is a registered trademark in China and several other countries under the symbol THINKCAR, and all other Thinkcar trademarks, service marks, domain names, icons and company names mentioned in this brochure are the property of Thinkcar and its subsidiaries. In countries where Thinkcar's trademarks, service marks, domain names, icons, and company names are not registered, Thinkcar disclaims ownership of unregistered trademarks, service marks, domain names, icons, and company names. Trademarks of other products and company names mentioned in this manual remain the property of the original registered companies. No one may use the trademarks, service marks, domain names, icons, or company names of Thinkcar Inc. or any other company mentioned without the prior written consent of the owner. You can visit the Thinkcar website: www.thinkcar.com, or by writing to: Shenzhen Headquarters: 2606 #4 block, Tian'an Cloud Park Bantian, Longgang District, Shenzhen, China Contact Thinkcar for written permission to use the manuals.

Contents

Safety..... 3

1. Introduction..... 4

1.1 Outline..... 4

1.2 Functions..... 4

1.3 Specifications..... 4

2. Functions..... 5

2.1 Primary Functions..... 5

2.2 Subsidiary Functions..... 5

3. Operation..... 5

3.1 Parts Descriptions..... 5

3.2 Circuit Diagram..... 6

3.3 First Use..... 7

3.4 Preparations Before Operation..... 7

3.5 Power On..... 8

3.6 Auto Mode..... 8

3.7 Cleaning..... 9

3.8 Recycle..... 9

3.9 Vacuum..... 10

3.9.1 Vacuum..... 10

3.9.2 System leakage detection..... 10

3.10 Add new oil..... 10

3.11 Recharge refrigerant..... 11

3.12 Database..... 11

3.13 System settings..... 11

3.13.1 Unit Setting..... 12

3.13.2 Maintenance..... 12

3.13.3 Language setting..... 14

3.13.4 Information Query..... 14

3.13.5 Help..... 16

3.13.6 Brightness Adjustment..... 16

3.13.7 Date and Time Settings..... 16



Safety

- A. The machine is designed to be used and repaired by qualified personnel only.
- B. The machine is designed to be used for R134a or R1234yf refrigerant. If you have used R134a and want to switch to R1234yf, You must replace it by Replace refrigerant type function, otherwise you will not be able to use another type of refrigerant.
- C. Fill the A/C system with the quantity of refrigerant recommended by the manufacturer.
- D. Check the vehicle user manual for the type of refrigerant. Do not mix different type of refrigerant otherwise it'll easily lead to malfunction of the machine.
- E. Keep away from moving parts and rotating elements such as cooling fans, alternators and heating components, etc to avoid harm.
- F. Wear protective clothing gloves and goggles.
- G. As automotive air conditioning pipe flushing, the operator must be fully familiar with automotive air conditioning system and operation of the machine. Check whenever the engine is turned off that the ignition key is turned to the full OFF position!
- H. Do not expose the machine to direct sunlight or rain. Use only in well-ventilated work areas.
- I. Never exceed 30 ° tilt in transit process upside down is strictly prohibited.
- J. Do not touch the machine high voltage power supply section, and do not maintain the machine as power on.
- K. Care of the manual.
- L. We reserve the right to modify the contents of this document without prior notice to our Customers.

1. Introduction

1.1 Outline

ThinkCar AC100(V3.0) A/C System Maintenance Centre is with the latest design technique which uses the best control principle and the manufacturing process.

ThinkCar AC100(V3.0) A/C System Maintenance Centre is intelligent equipment collecting of the A/C flushing, recovery, recycling, recharging and other functions in one. It's with the beautiful shape, humanized operation interface, and advanced manufacturing processes to make the A/C maintenance professional and simple.

1.2 Functions

- A. Fully automatic, easy to operate.
- B. Internal pipeline of A/C system flushing, effectively cleared the internal greasy and fouling, to restore the A/C system performance.
- C. With forward flushing and reverse flushing functions, which greatly improve the cleaning effect.
- D. Vertically installing the HP & LP gauges let the operator be able to observe the pressure parameters timely even in the car.
- E. Unique design of the pipeline to achieve the high recycling rate no matter with the gas or the liquid.
- F. Easy to operate with the concise operating interface.
- G. Designed with large size LCD.
- H. Built in database for easy maintenance and calling.
- I. Program and database can be updated.
- J. With printer.

1.3 Specifications

- A. Working conditions:
 - Ambient temperature: 10~50°C
 - Relative humidity: < 85%
- B. Voltage input: AC220V±10%~50/60Hz AC110V±10%~50/60Hz **(According to the equipment nameplate)**
- C. Compressor power: 3/8HP
- D. Vacuum pump: 42L/Min, 5Pa (for 220V); 50L/Min, 5Pa (for 110V)
- E. Load cell for tank: ±10g
- F. Load cell for oil bottle: ±5g

- G. Tank: 12L
- H. New oil bottle: 300ml
- I. Used oil bottle:500ml
- J. LCD display: 800*480
- K. Working pressure: max. 20bar
- L. HP/TP gauge: -1bar~38bar
- M. LP gauge: -1bar~18bar

2. Functions

2.1 Primary Functions

- A. Auto Mode
- B. Cleaning
- C. Recycle
- D. Vacuum
- E. Add new oil
- F. Recharge refrigerant
- G. Database
- H. Print

2.2 Subsidiary Functions

- A. System function
- B. Discharge non-condensable gases
- C. Machine maintenance procedures
- D. Equipment info inquiry
- E. Help

3. Operation

3.1 Parts Descriptions

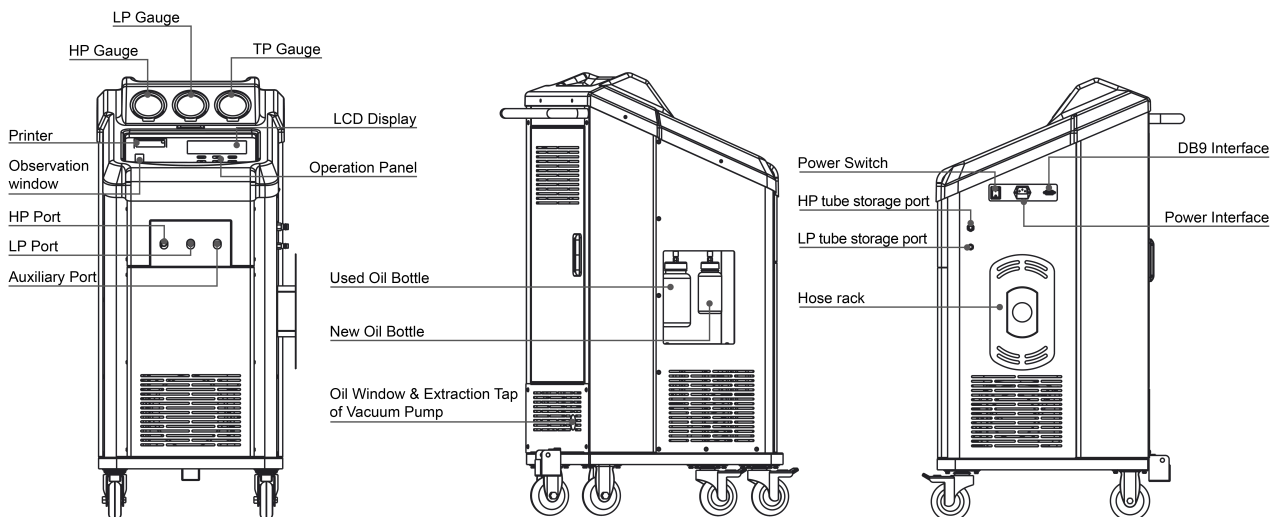

3.2 Circuit Diagram

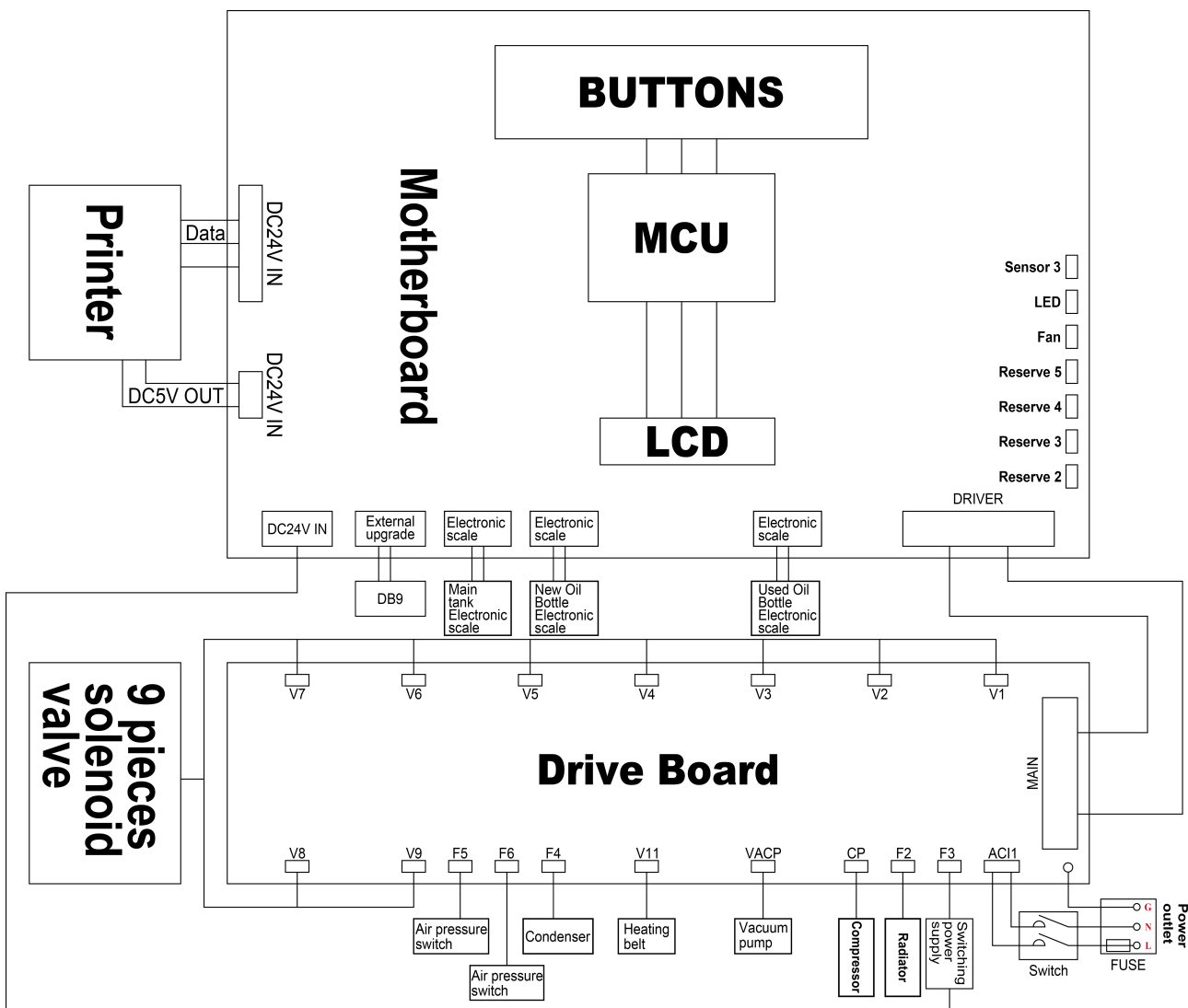

3.3 First Use

A. Set the language: select one and press **ENTER**.

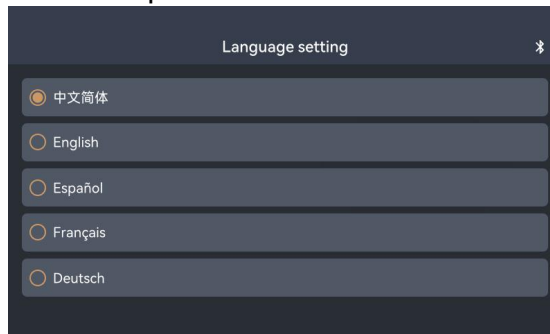

B. Set the refrigerant type: select one you will use and press **ENTER**.

Warning: After confirming one type refrigerant, if you need to replace another type of refrigerant, you must firstly discharge the refrigerant from the equipment by replace refrigerant type function. Otherwise, another type of refrigerant cannot be used.

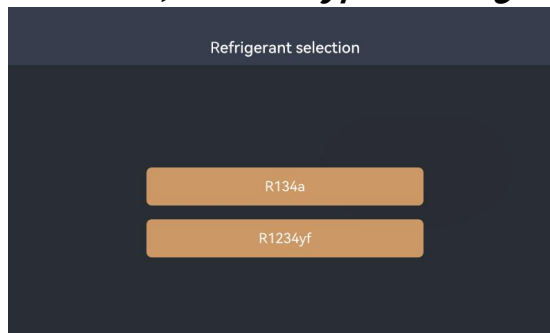

C. Set the units: select one and press **ENTER**.

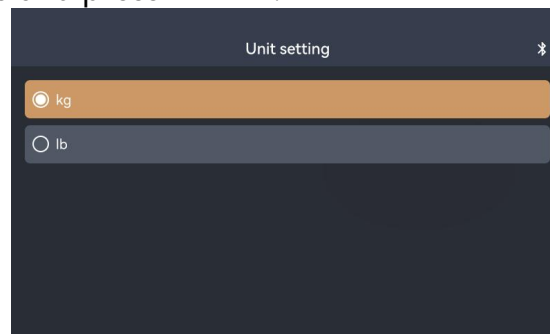

D. Please supply about 3 kg refrigerants into the tank of equipment so that all of the functions can be run normally. Please refer to the chapter of “**Add main tank refrigerant**”.

E. Please read this user manual carefully before operating.

3.4 Preparations Before Operation

A. Connect the high/low pressure refrigerant pipes of the equipment to the high/low pressure valve interfaces of the car air conditioning system, and unscrew the high and low pressure joints for conduction. Start the car, turn on the air conditioning, and idle for about 5 minutes.

B. Check if the high and low pressure of the car air conditioner are normal, and check if







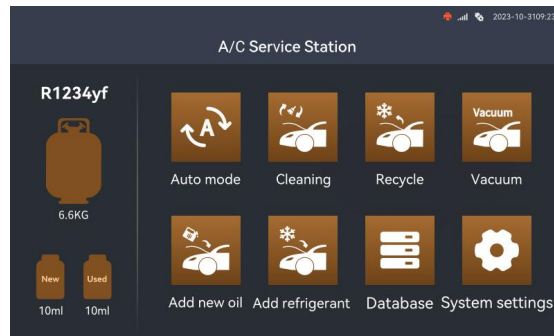

there is any abnormal noise when the compressor is working. If there is any abnormality, it must be repaired first.

- C. Turn off the air conditioning and turn off the engine.
- D. Empty the waste oil from the old oil bottle of the equipment. Power on the device and prepare for work.

3.5 Power On



Description:

	Auto Mode Automatically all the process.		Add new oil Fill the new oil into A/C system.
	Cleaning Clean the internal pipelines of the car air conditioning system.		Recharge refrigerant Recharge quantitative.
	Recycle Recycle the refrigerant of A/C system.		Database Inquiry the automotive refrigerant type and filling amount, the refrigerant oil type and filling amount.
	Vacuum Timing Vacuum.		System settings Exchange dry-filter, pipe-line cleaning, calibration load cell.

3.6 Auto Mode

- A. Under this mode, all of the functions can be run full automatically after setting the parameters.
- B. Before running, must drain out the used oil entirely and fill enough new oil into the new bottle.
- C. Operations:

C-1: Select the **Auto Mode** Function  and press the **ENTER** key to enter the function

menu.

C-2: Set the all parameters.

C-3: Press the **ENTER** key to start.

D. When finished, it'll stop automatically.

3.7 Cleaning

A. By this function, it will be able to clean out the refrigerant oil and oil sludge to exchange the refrigerant entirely to improve the performance of compressor. And also it will recover the refrigerant remained in the A/C system.

B. Before flushing the pipeline of automotive A/C system, please turn on A/C system and run it for 5 to 10 minutes. And set it as the lowest temperature and medium wind.

C. Turn off the automotive air conditioning.

Warning: do not start the air conditioning during the flushing process! Otherwise, it easily causes damages to the air-conditioning and risk of accident!

D. In order to achieve good flushing performance, it is generally recommended to clean air conditioners with only front exhaust vents at least once, and air conditioners with rear exhaust vents at least twice. The more and longer the cleaning times, the better the cleaning effect.

Note: The flushing takes about 30 minutes. This time does not include the time spent in the recycling process before and after the cleaning process.

E. Operations:

E-1: Select the **Cleaning** Function  and press the **ENTER** key.

E-2: Set the cleaning times.

E-3: Press the **ENTER** key to start.

F. When finished, it'll stop automatically.

Notice: it's normal for that there have action sound of the solenoid valve during the working process. Please do not stop it. The used oil can be drained out automatically.

Warning: If there is a sudden power outage or unexpected termination during the cleaning process, please perform the cleaning function again and do not operate other functions.

3.8 Recycle

A. By this function, it will recover the refrigerant remained in the A/C system.

B. Operations:

B-1: Select the **Recycle** Function  and press the **ENTER** key.

B-2: Press the **ENTER** key to start.

- B-3: After **Recycle** over, it'll drain the used oil automatically.
- C. When finished, it'll stop automatically.

3.9 Vacuum

3.9.1 Vacuum

- A. By this function, it will clean the water vapor out from the A/C system.
- B. It should be more than 15 minutes. Generally, it needs 15 minutes at least for the air conditioning only with front wind and 20 minutes for with the front and rear wind.
- C. Operations:
 - C-1: Select the **Vacuum** Function  and press the **ENTER** key.
 - C-2: Set the vacuum time.
 - C-3: Press the **ENTER** key to start.
- D. When finished, it'll stop automatically.

3.9.2 System leakage detection

If necessary, you can select the system leakage detection function to detect leakage in the vehicle's air conditioning pipelines. Please follow the steps as below:

- A. Select vacuum function  and press **ENTER**.
- B. Set the system leak detection time.
- C. Press **ENTER** to start to run the function, the system will automatically perform pressure rise leak checks after vacuuming.

Note: Vacuuming for less than 15 minutes will result in inaccurate leak detection.

When the pressure rises by more than 0.3 bar during leak detection process, it is determined that there is a leak in the system and an alarm will be issued.

3.10 Add new oil

- A. It must be able to do after vacuum process.

Warning: please do not press the switch of the new oil bottle anytime when the automotive air conditioning system is not in vacuum state, otherwise it have the risk of explosive bottles!

- B. Pour new oil into the new oil bottle.

Note: add new oil more 20ml than the used oil drained out to avoid the air into the air conditioning system.

- C. Method 1: Control by manual. Long press the **Add new oil** button to gradually add new oil to the car's air conditioning system.
- D. Method2: Control automatically.

- D-1: Select the **Add new oil** Function  and press the **ENTER** key.
- D-2: Set the adding amount.
- D-3: Press the **ENTER** key to start.

3.11 Recharge refrigerant

- A. Select the **Recharge refrigerant** Function  and press the **ENTER** key.
- B. Set the recharge amount.
- C. Press the **ENTER** key to start.
- D. When finished, it'll stop automatically.

Note: The recharging amount setting as following.

Method 1: Set the amount directly.

Method 2: Set the amount by the database. Steps as following:



3.12 Database

Select the **Database** Function , you can query the refrigerant type and filling amount, the refrigerant oil type and filling amount of relevant vehicle models' A/C.

3.13 System settings

Select **System settings**  and execute various settings menus as needed.

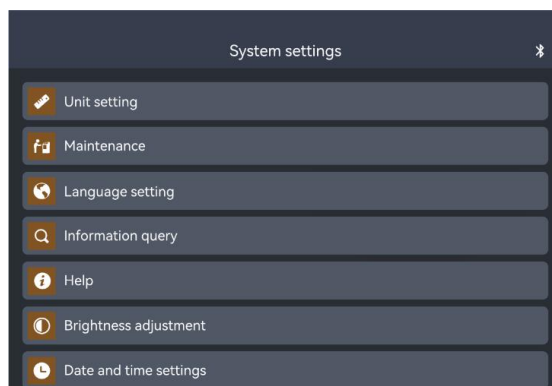

3.13.1 Unit Setting

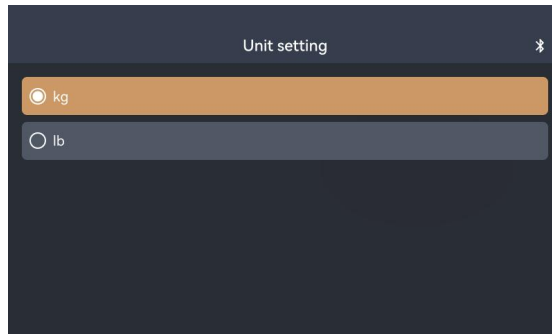

Change the units.

3.13.2 Maintenance

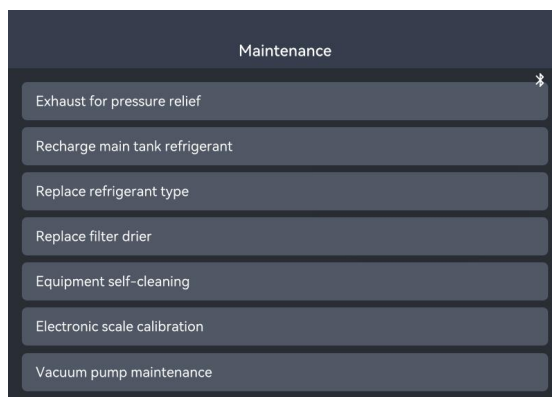

1. Exhaust for pressure relief

When the machine appear the High-pressure Alarm, this function can be executed to relieve pressure on the system.

2. Add main tank refrigerant

- A. If the refrigerant amount in the main tank is less 3kg, the flushing function can't run any more until supply enough refrigerant into the machine.
- B. There have two ways to supply the refrigerant.

Method 1:

M1-1: Connect the port of fresh refrigerant tank to the LP port of equipment.

Note: it should connect to the liquid port of fresh refrigerant tank. If has no liquid port, please place the fresh refrigerant tank upside down.

M1-2: Block the HP port of equipment with a cap.

M1-3: Select supply main tank function and then set the supplying amount.

Note: Amount of supplying: Setting the amount according to remain amount in the tank.

M1-4: When alarming, please close the valve of the refrigerant tank and until finished automatically.

Method 2:



Use the supplying connecter

M2-1: Fitting the supplying connecter to the port of fresh refrigerant tank.

Note: it should connect to the liquid port of fresh refrigerant tank. If has no liquid port, please place the fresh refrigerant tank upside down.

M2-2: Connect the HP (or LP) coupler to the supplying connecter.

M2-3: Select the Recycle function and run it.

M2-4: When you see the total amount more than 4.5kg, close the valve of the refrigerant tank and until finished automatically.

Note:

Main Tank: the tank is installed in the machine which is used for the flushing, Recycle, recharging functions.

3. Replace refrigerant type

If you want to use another type refrigerant, you must do this function. Please operate following the prompts step by step.

4. Replace filter drier

- A. The dry filter must be exchange when it reaches the life time. There will give a message.
- B. If not exchange the dry-filter timely, it will not be able to run the Recycle, flushing and supplying functions.
- C. Operations:
 - C-1: Select Exchange dry-filter Function and press **ENTER** key.
 - C-2: Input the ID of the dry-filter: 1000.
 - C-3: And then do step by step as the information.

Note: Please attention the mounting direction of the dry-filter.

5. Equipment self-cleaning

- A. After a period of use, such as 2months, it should be run this function.
- B. It can clean up the pipe line of the machine.

Note: Connect red refrigerant pipe and blue refrigerant pipe into one pipe with two-way connector.

6. Electronic scale calibration

- A. When the load cell is not precise, it needs to be calibrated.
- B. You need input the password 1000 before use this function.
- C. If do the calibration of main tank load cell, please prepare a 10~20kg weight.
If do the calibration of oil bottle load cell, please prepare a 1-3kg weight.
- D. Follow the prompts step by step.

Note: if here have some programs, please check according to the messages.

7. Vacuum pump maintenance

- A. When the pump oil became cream or machine display maintenance message, the vacuum pump oil must be changed.
- B. If not change the pump oil in time, the vacuum pump will be easily damaged.
- C. Steps:
 - C-1: Open the back-down cover.
 - C-2: Unscrew the cap of the fill port and then fill the new oil slowly into the vacuum pump until the oil level reach at the center site. Then re-back the cap to the fill port.

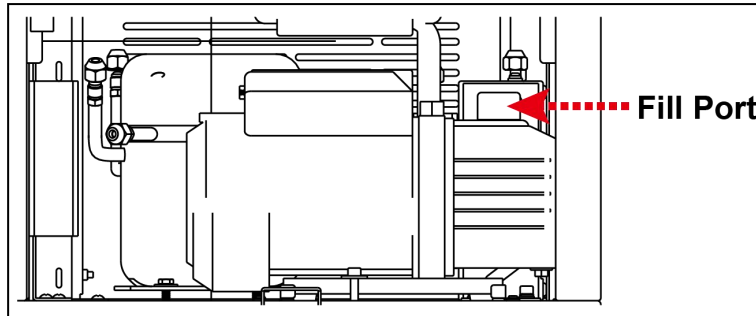

Note: the new vacuum pump oil cannot be filled too much into the vacuum pump otherwise it will spray out when working.

C-3: Re-back the cover.

8. System leakage detection

This function is used to perform the system leakage detection.

3.13.3 Language setting

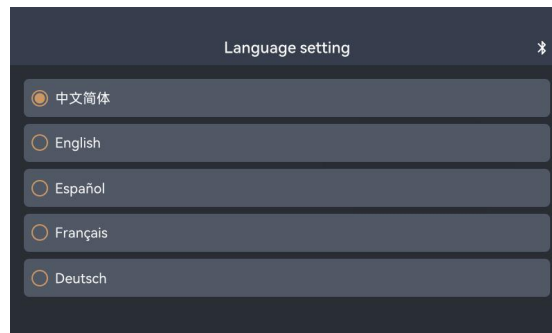

Change the language.

3.13.4 Information Query

This function is used to view information such as device usage, software version, hardware version, serial number, and service provider.

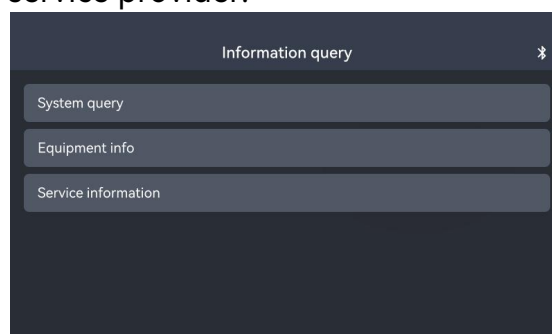

1. System Query

Here you can check the working status of the machine.

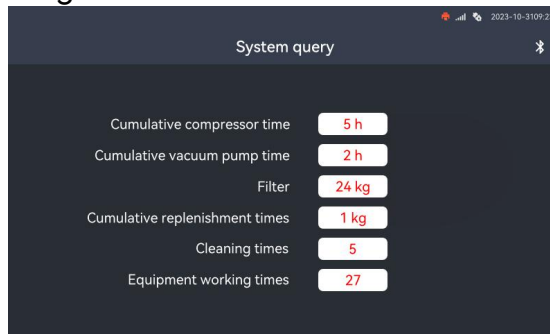

2. Equipment info

Here you can check the **SN**, hardware version, software version etc.



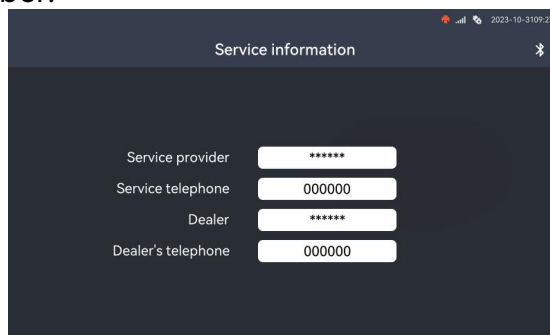

3. Service Information

Through this function, you can view and edit relevant information such as service providers and service telephone number.



Editing function operation steps are as below:

- Press the  and  keys at the same time until the cursor appears in the input box, it enters editing mode.
- In editing mode, you can use the up and down keys to switch between a-z, A-Z, 0-9, and some special symbols for input purposes.
- If you need to modify the content of a certain location, you can use the left and right keys to move the cursor to the target location, and then follow step B to edit.
- If you need to delete a certain content, you can set the content to a space, so that to achieve the purpose of deletion.

E. After completing all edits, please remember to click the **ENTER** button to save the information, otherwise the changes may be lost.

Note: Please be careful when performing editing operations to avoid errors in customer information due to incorrect operation.

3.13.5 Help

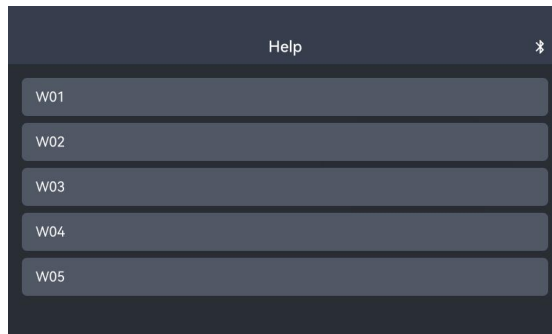

Here you can check all of the help messages.

3.13.6 Brightness Adjustment

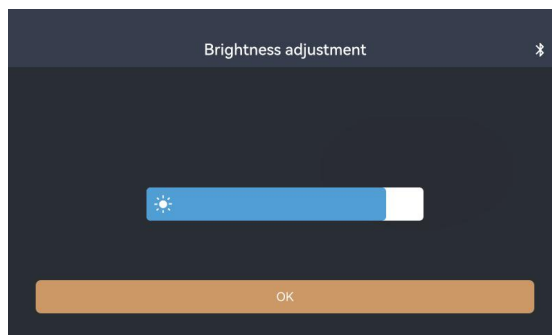

This function is used to adjust screen brightness.

3.13.7 Date and Time Settings

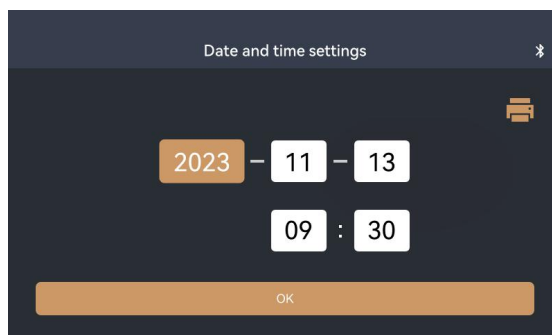

This function is used to set the time and date.

Warranty terms

This warranty applies only to customers and dealers who have purchased Thinkcar products through the normal course of business.

For a period of one years from the date of delivery, Thinkcar Inc. warrants its electronic products against damage caused by defects in material or workmanship. Damage to this equipment or parts caused by misuse, unauthorized alteration, use for purposes other than those for which the product was designed, or failure to operate in the manner specified in the instruction manual is not covered by this warranty. Damage to automotive gauges caused by defects in this equipment is limited to repair or replacement only, and Thinkcar is not liable for consequential or incidental damages. Thinkcar will determine the nature of the damage to the equipment in accordance with its own prescribed methods of inspection. No agent, employee, or commercial representative of Thinkcar is authorized to make any confirmation, recommendation, or promise in connection with Thinkcar products. No agent, employee or commercial representative of Thinkcar is authorized to make any confirmation, representation or promise with respect to Thinkcar products.

Waiver of Declaration

The above warranty may be substituted for any other form of warranty.

Order Notification

Replacement parts and optional accessories can be ordered directly from Thinkcar authorized dealers, please specify the quantity, part number and part name.

Customer service center

If you encounter any problems during the operation of the equipment, please call: 1-909-321-5665.

When the equipment needs to be repaired, please send it to Thinkcar with the warranty card, product certificate, purchase invoice and a description of the problem. If the equipment is within the warranty, Thinkcar will repair it free of charge; if the equipment is outside the warranty, Thinkcar will charge for the repair and add the return shipping cost.

SIMPLIFIED EU DECLARATION OF CONFORMITY

Hereby, THINKCAR TECH CO., LTD. declares that this equipment is in compliance with Directive 2014/53/EU.

The full text of the EU declaration of conformity is available at the following internet address:

https://h5.mythinkcar.com/update_app/productlist

Thinkcar Company Address:

1908 S Lynx Pl, Ontario, CA 91761

Customer Service Email: service@thinkcar.com

Thinkcar website: www.thinkcar.com

Statement:

Thinkcar reserves the right to change product design and specifications without prior notice. The appearance and color of the actual product may differ from that shown in the manual, please refer to the actual product. We have tried our best to make all the descriptions in the book accurate, but there are still some inaccuracies, if you have any questions, please contact the dealer or Thinkcar after-sales service center, the company does not assume any responsibility for any misunderstandings arising from the consequences.